

TECHNICAL FEATURES

- ✓ Reflective quartz: 25 mm;
- ✓ Accuracy: 5";
- ✓ Quartz color: white;
- ✓ Frame material: anodized aluminium;
- ✓ Maximum range: up to 500 m (according to the instrument used);
- ✓ Fixing: 42x40 mm anchoring plate, with central 6 mm hole and 3 mm holes on the plate corners.



The mini prism is made up of a 25 mm diameter white reflective quartz mounted on anodized glossy aluminium.

The structure is mounted on a U-shaped adjustable bracket, with an oblique adjustable cover for protection against sunrays, rain, snow.

Ideal for installation in urban areas (its special shape makes it perfectly suitable) and designed for use in

automatic monitoring systems with robots units for periodic readings.

+17.5 mm Leica offset, -16,9 mm absolute offset (the mini prism orientation must remain fixed after installation).

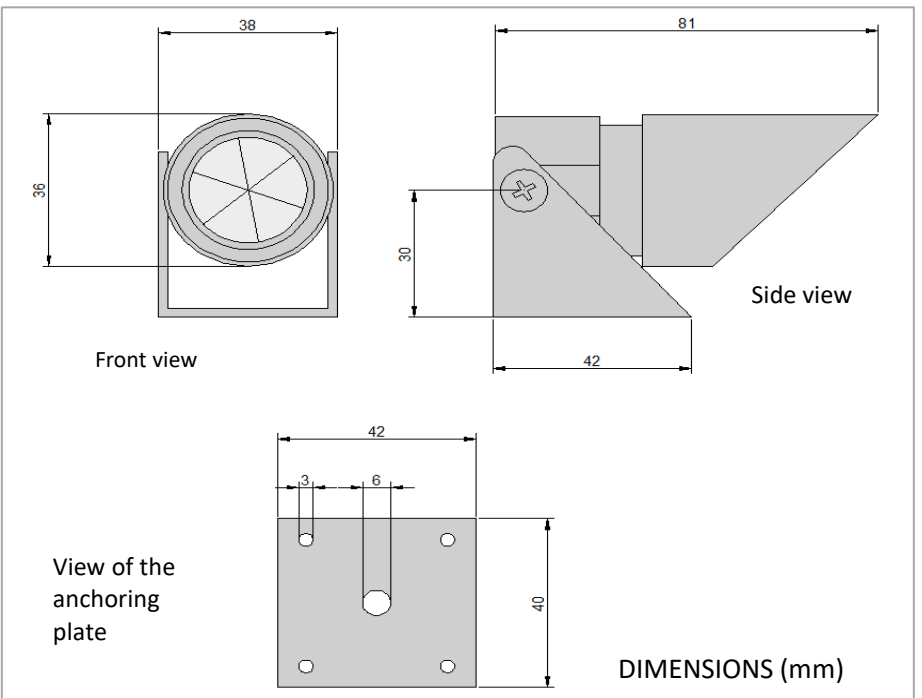

We reserve the right to carry out modifications to our products and their

CE product compliant with European directives