

TECHNICAL FEATURES

- ✓ Measuring range: 350-2500 kN;
- ✓ Cell plate: with 16 strain gauge sensors;
- ✓ Wheatstone bridge: input resistance 1450 + 50 Ω;
- ✓ output resistance 1400 +/- 5 Ω;
- ✓ Nominal sensitivity: 2.0 mV/V +/- 0.15%;
- ✓ Output signal: mV/V, 4-20mA;
- ✓ Combined error (total accuracy): <+/- 0.3% F.S.;
- ✓ Repeatability: +/-0,015% F.S.
- ✓ Maximum deflection under load: 0.4 mm;
- ✓ Material: stainless steel;
- ✓ Power supply 5-15 V DC;
- ✓ Operating temperature: from -20 to +70°C;
- ✓ Insulation resistance: >5GΩ;
- ✓ Temperature coefficient of zero: +/- 0.005% F.S./°C;
- ✓ F.S. temperature coefficient: +/- 0.005% F.S./°C;
- ✓ Protection level: IP68.



The anchor load cell is a ring-shaped instrument in stainless steel.

These cells are mainly used to check the tension of strand and bar anchoring systems in medium and long term monitoring sites.

The cell is features a series of strain gauges in full Wheatstone bridge configuration providing an electrical signal proportional to the load applied.

It is provided with a cable. Please specify

the length of the required when you place your order.

The size of the cell's hole must be selected according to the load of the anchoring system and the dimension of the sensitive ring.

CROSS-SECTION VIEW

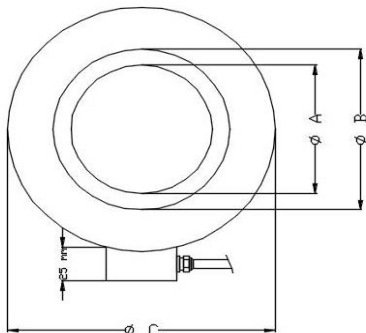
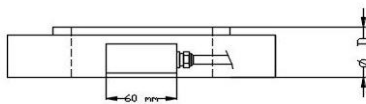

VIEW FROM ABOVE

 product compliant with European directives

DIMENSION SPECIFICATIONS AND FULL SCALE

Code	Measuring range (XXXX)	Diameter hole (mm)	Sensitive ring diameter (B)	External diameter (C)	Thickness (D)
	kN	mm	mm	mm	mm
CCT-02-165-XXXX	from 500 to 2500	165	190	260	40
CCT-03-120-XXXX	from 350 to 1800	120	135	200	40
CCT-07-40-XXXX	from 350 to 750	40	91	155	40

We reserve the right to carry out modifications to our products and their specifications without